

PTWS 1420

USP/EP Tablet Dissolution Testing Instrument

The PTWS 1420 is a 14+2 position, “dual drive” compact tablet dissolution testing instrument for solid dosage forms as described in USP chapter <711/724> and EP section <2.9.3/4> as well as the BP, DAB and Japanese Pharmacopeia section <15>. The instrument features 14 testing position and includes two additional standard size vessels for media refilling and reference standard media. PTWS 1420 features independent stirrer speed control for the left and right half of stirrers.



Perfect Biowaiver Solution

PTWS 1420 is the first tablet dissolution testing instrument from Pharma Test featuring 14 full size stirred vessel positions. The vessels are arranged in a two times 6+1 configuration. This way not only your samples but also the standard or reference media will be heated and stirred by the instrument. In addition PTWS 1420 features two additional heated vessels to store the replacement media for systems including an auto sampler. This way also the replacement media which is filled into the vessels after sampling has the same temperature as the test media eliminating any influence on the dissolution test due to the refilling of cold media.

The 14 vessel design of PTWS 1420 makes this instrument an excellent choice for Biowaiver applications and for offline automated systems.

Password Controlled

Access to the instrument can be password controlled if required. If certain operational parameters form a regular feature of the daily routine, then these can be incorporated into a test method for faster set up. These parameters can be tool speed, target bath temperature, sampling time points and so on. The test method memory capacity is almost limitless. As soon as the test is started, a screen saver can be activated with the most important information displayed in large script so that this information remains visible even at time when the operator is not standing directly in front of the instrument.

User Interface

In keeping with our cutting edge design, a large color, touch screen allows control of the various mechanical features of the instrument such as the tool stirring speed, lift drive and heater. The instrument control is menu driven using a resistive touch screen and selection wheel technology. Visual signals on the display inform the user of the status of critical instrument parameters, e.g. bath target temperature not reached. Access to the instrument can be password controlled if required.

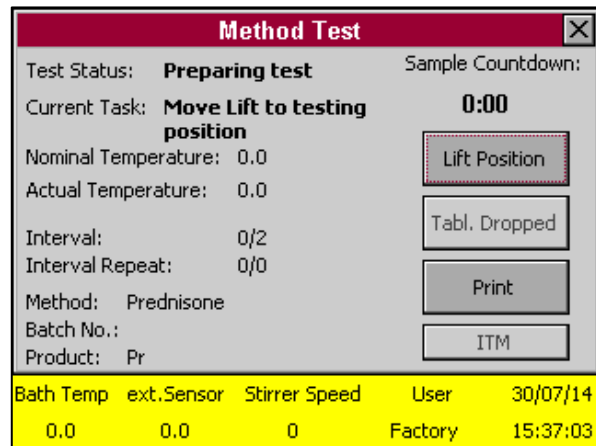

As soon as the test is started, a screen saver can be activated with the most important information displayed in large script, like count-down timer so that this information remains visible even at time when the operator is not standing directly in front of the instrument.



Stirring Tools

The PTWS 1420 uses the Pharma Test MonoShaft™ design. Tools consist of the main shaft plus interchangeable tool heads (adapters). The main shaft remains in place in the instrument regardless of the tool head being used. The clearance of each tool from the vessel base will always be correct once the main tool shaft has been installed and qualified with any one of the tool sets once. Each stirrer can be raised by hand into a convenient position for easy vessel removal or insertion. PTWS 1420 is capable to perform a staggered start for each of the 14 positions, which is essential in manual operation.

Auto Vessel Centering System

The PTWS 14200 features a new auto vessel centering system using a plastic ring which serves to both hold and center the dissolution vessel. The access points for sampling as well as the openings for the tools are contained in an auxiliary, low evaporation, vessel cover. Each USP Borosilicate glass vessel has a batch code on top of the flange for easy visibility and positioned placement inside the water bath cover.

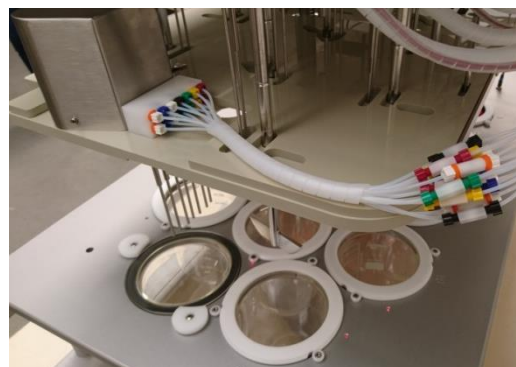

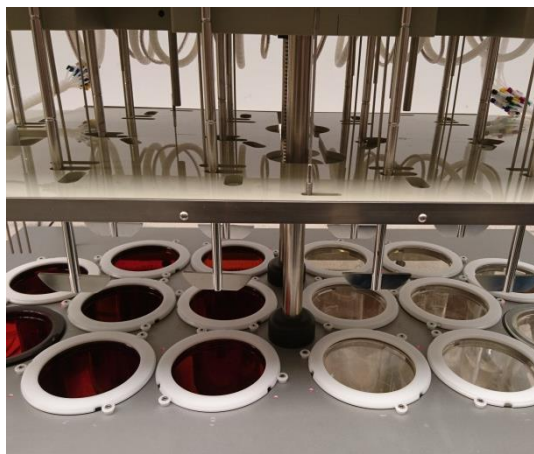

Lift Mechanism

The upper drive is motorized and electronically controlled it offers eight programmable positions: an upper cleaning and instrument qualification position and lower working positions are programmable depending on the type of stirring tool used. The upper position offers ideal access to the stirring tools and vessels for a change of tools and cleaning steps between the dissolution tests. The motorized drive head lifting mechanism is positioned in a way so that the tool shafts are always kept parallel and at a 90° angle to the vessel walls when in the working position.

Automation Capabilities

The motorized EPE-1420 sampling system lowers the sampling probes into the media and after sampling raises them back out again. Up to 8 different sampling positions can be programmed. The ITM-1420 individual media temperature monitoring system is attached to the EPE-1420 and will read and report the vessel media temperatures in all 14 vessels while sampling. The motorized TMA-1420 tablet dropping magazine completes the set of useful accessories for automation. The magazine insures the simultaneous drop of up to 14 samples. It covers all vessels and ensures low evaporation rates during the dissolution test. The magazines include magnetic holders for the tube cleaning device.

Offline Sampling and Sample Preparation

For offline automation with fraction collection the PTFC-16 fraction collector as well as either PT-SP multiple syringe pumps, an IPC peristaltic pump, or a CAT piston pump can be added to the PTWS 1420. Using the PTWS 1420 within an automated system offers the operator full access to the vessels before and at the end of a run as the complete drive head is lifted electronically. Sampling sequence timing is programmed using the menu system of the PTWS 1420 instrument, while sampling volume and the optional media refilling process is programmed at either the PTFC-16 or DSR-M. No external software is necessary in this system. The motorized sampling system EPE-1420 is used to lower the sampling probes while sampling into the dissolution vessels. When sampling is finished the sampling probes are raised out of the media and the system waits for the next cycle. Each sampling probe holds a PP sinter filter (usually 5 or 10µ). When the tablets have been dropped into the dissolution vessels the automated sampling process starts. If the refilling option is used media refilling will start automatically after a sample has been withdrawn.

Connection to Dissolution Sampling Robot

It is also possible to use the DSR-M dissolution sampling robot which features the capability of sample dilution and media refilling. The DSR-M offers excellent sampling and refilling accuracy via the fully integrated valve-less piston pump module. Sampling time and interval control is programmed the PTWS 1420 while volume, dilution ratio and refilling option are set at the DSR-M instrument.

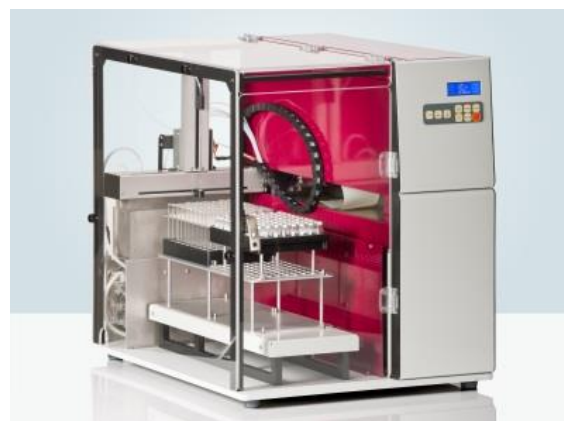

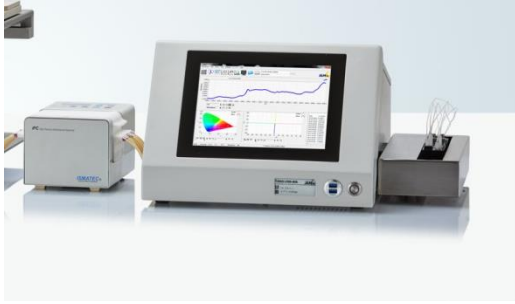

ADS-L Closed Loop Online Systems

For an online automated system it is possible to use the J&M TIDAS L UV/VIS spectrometer with a 16 position multiple-cell-changer. The spectrophotometer and pump of such a system is controlled by the powerful WinDiss ARGUS dissolution software running on the integrated PC of the TIDAS L spectrometer.

Space Requirements

A key point in today’s crowded labs is the footprint of the PTWS 1420 compared to two conventional dissolution baths:

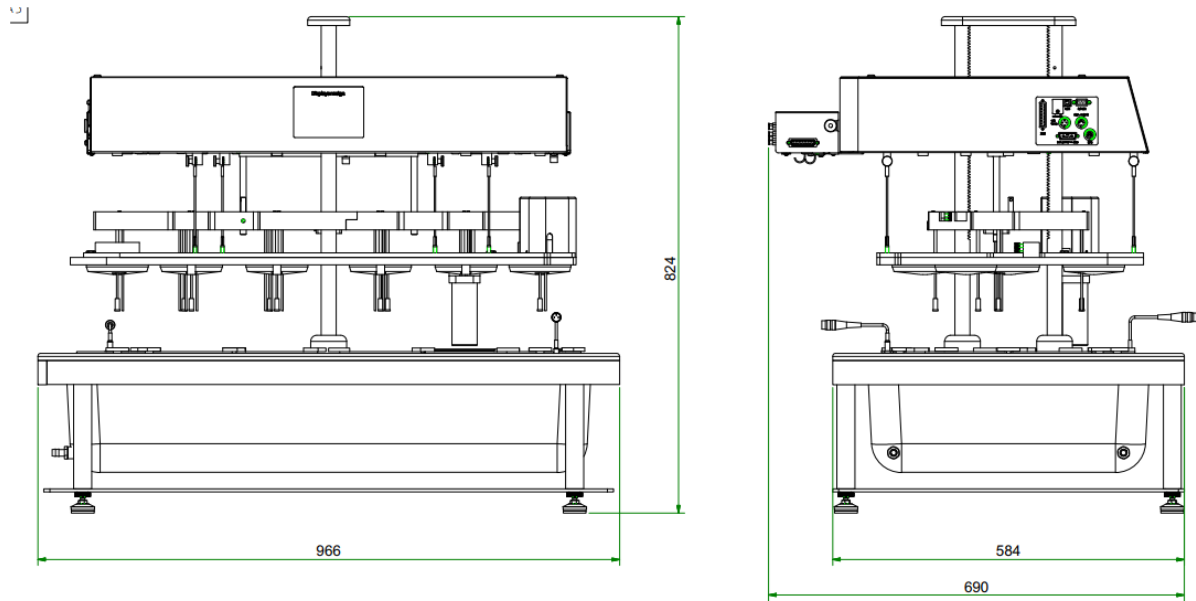

With less than 100cm of total width for the main instrument, PTWS 1420 features a sturdy design and yet makes optimal use of the limited space available in a typical laboratory.

Advantages

- » 14 stirred vessels in one instrument is ideal for Biowaiver applications and offline automated systems
- » Dual drive configuration with independent speed control for left and right side of instrument enables flexible use of the PTWS 1420
- » Replacement media is stored in two additional heated vessels eliminating influences from cold media refilling
- » Easy to use auto vessel centering system
- » Eco friendly double walled vacuum molded water bath for improved temperature insulation
- » Screen saver functionality offers most important information at a glance (stirrer speed, bath temperature, time to next sampling interval, elapsed time, media temperature etc.)
- » Wake up functionality to start heating at a pre-programmed time
- » Programmable infinity test
- » MonoShaft™ system to avoid re-adjustment of immersion depth after tool exchange
- » Staggered start feature for convenient manual sampling
- » Water diffuser for even temperature distribution
- » IQ/OQ documents included free of charge

Features

- » Fully USP <711/724> and EP <2.9.3/4> compliant
- » 14 stirred vessel positions, 2 additional heated vessels for replacement media
- » Dual drive configuration with two stirrer motors
- » CAN Bus technology offering instrument suitability check prior to start of a test run
- » Staggered start capability
- » Vessel low evaporation sealing covers
- » Removable water bath for easy cleaning
- » Drainage tap to empty the bath
- » Method management and user administration
- » User access control
- » Optical and acoustic signals to inform about sampling intervals, timer count down function
- » Traffic Light optical information on display shows the instrument status by different colors (green = ready to use, yellow = preparing to use, red = error encountered)
- » OQ, PQ interval warning with programmable interval
- » Interfaces: USB port for remote control of the PTWS 1420, RS232 port to connect serial devices, I/O port for remote control of external instruments in automated applications, like DSR-M, pumps and PTFC-16
- » Calibration menu for stirrer speed, bath temperature and more

Standard Scope of Supply

The PTWS 1420 comes ready to use with the following standard scope of supply:

- » One set of 14 stainless steel paddles
- » One set of 16 batch coded 1000ml Borosilicate glass vessels
- » One set of depth adjustment balls
- » One bottle of ALGEX Magenta water preservative
- » Comprehensive documentation folder including:
 - › User manual
 - › DQ/QC instrument compliance test certificate
 - › IQ documentation
 - › OQ documentation
 - › Instrument logbook
 - › Compliance certificates for vessels and stirring tools

Options

In addition to the standard scope of supply Pharma Test offers a broad range of accessories and options including:

- » Direct control of peripheral instruments via I/O port such as PTFC-16 fraction collector or DSR-M Dissolution Sampling Robot
- » EPE-1420 automated sampling manifold that automatically moves into the programmable sampling position at the programmed intervals
- » TMA-1420 automated tablet drop magazine to ensure simultaneous insertion of up to 14 samples
- » ITM-1420 individual temperature measuring device with individual temperature probes to automatically measure the vessel temperatures of all 14 vessels while sampling
- » 250ml MiniVessel set incl. mini paddle stirrers
- » Amber colored vessels for UV sensitive test materials
- » Full range of MonoShaft™ stirring tools available
- » Full range of certified validation tools available
- » Cleaning system for sampling probes and tubing featuring magnetic holders
- » PT-RP80 serial report printer

PT-RP80 Report Printer

Use the PT-RP80 serial report printer to print out the runtime report of the PTWS 1420.



Example Runtime Report

<p>RUN TIME REPORT =====</p> <p>PHARMA TEST PTWS1420 S/N: 22018 V: 1.00</p> <p>PRINT DATE/TIME: 02.06.2018 12:31:48 USER NAME: ADMIN PRODUCT NAME: PRODUCT1 METHOD NAME: METHOD1</p> <p>BATCH: 1 BATH TEMP NOM.: 37.0 BATH TEMP ACT.: 36.9 LIFT: USP 1 VOLUME: 900ml DURATION: 0:10 SPEED NOM1: 50 SPEED 1: 50 SPEED NOM2: 100 SPEED 2: 100</p> <p>I.-COUNT1: 1 I.-DELAY1: 0:01 I.-COUNT2: 1 I.-DELAY2: 0:02 I.-COUNT3: 0 I.-DELAY3: 0:00</p> <p>TEST STATUS: NO ERRORS</p> <p>START: 02.02.2015 12:21:08 END: 02.02.2015 12:31:08</p> <p>INT.1: 02.02.2015 12:22:08 BATH TEMP ACT.: 36.8</p> <p>INT.2: 02.02.2015 12:24:08 BATH TEMP ACT.: 36.9</p> <p>OPERATOR NAME</p> <p>SIGNATURE</p>	<p>Type of the instrument (PTWS 1420) Serial number of the instrument Firmware version installed on the instrument</p> <p>Date and time of this print out Name of the user currently logged in Name of the product used for this test Name of the method used for this test</p> <p>Batch number entered at the start of this test Nominal bath temperature from the method for this test Actual bath temperature at time of the print out Name of the lift position from the method for this test Media volume from the method for this test Total duration time setting for the method for this test Nominal speed setting from the method for this test</p> <p>First interval count First interval delay Second interval count Second interval delay Third interval count Third interval delay</p> <p>Current status of the test, if test is still running it will be "IN PROGRESS" Start date and time of the test End date and time of the test (if already finished)</p> <p>Occurrence of first interval Date and time of first interval Actual bath temperature when first interval occurred</p> <p>Occurrence of second interval Date and time of second interval Actual bath temperature when first interval occurred</p> <p>If no intervals have yet occurred it will be "NO INT"</p> <p>Space to write down name of the operator</p> <p>Space for the operator's signature</p>
---	--

Technical Specifications

Parameter	Specification
Display	6", 320x240 pixel color LCD, illuminated
Data Entry	Resistive touch screen, functional touch keys
Acoustic Signal	Programmable acoustic signal for operator information
Timer	Programmable sampling times, wake-up and sleeping mode, operation time information and timer count-down mode
Stirrer Position	8 programmable stirrer immersion positions (paddle over disk, transdermal cylinder etc.)
Testing Method Programming	Unlimited number of different test descriptions can be stored on SD card
User Access Control	Multiple level access control, CFR compliant
OQ, PQ control	Programmable time periods to remind on QO or PQ testing
Printer	External PT-RP80 report printer using long-life printer paper
Number of Stirred Vessels	14 vessels in a 2x 6+1 arrangement
Number of Additional Vessels	2 unstirred and heated vessels to store replacement medium
Standard Vessels	1 liter USP/EP Borosilicate glass vessel, each individually coded
Vessel Covers	Ultra-low evaporation design (< 0.7% within 24h)
Stirring Speed Control	25 - 250 RPM, independent speed setting for left and right side of instrument
Speed Accuracy	±2% of set speed, typically < 1%
Stirrer Shaft Wobble	Better than 0.2 mm total run out
System Tools	MonoShaft™ stirrer design, USP/EP apparatus 1, 2, 5, 6 tool adapter, cream cell, transdermal patch tools, each tool and vessel individually coded
Heating System	Pump for water circulation and 1500W heater for fast heating up (230/240V units only)
Heater Range	25 - 45°C
Heater Accuracy	± 0.2°C inside the water bath
Heat Up Process	Energy saving, programmable "wake up" heater function and "sleep mode"
Water Circulation	Water circulated from external heating system through special diffuser inside the water bath
Vibration Elimination	External heating system, spring loaded pump assembly
Calibration	Built-in calibration procedures for speed, temperature control, OQ/PQ interval programmable including alarm indicator
Instrument Dimensions	Bath: approx. 97cm x 69cm x 82cm (width x depth x height) Heater: approx. 26cm x 37cm x 21cm (width x depth x height)
Net Weight	Approx. 105 kg
Certification	All components certified to USP / EP requirements
CE / EMC Certification	All CE / EMC Certification provided
Validation	All IQ & OQ documents included

We reserve the right to make technical changes without any prior notice.