



Incubating Light Duty Orbital Shakers



Save Incubator Space with Benchtop Orbital Shakers

OHAUS Incubating Light Duty Shakers are designed to incubate samples from 5°C above ambient to 65°C. The Incubating Light Duty Shaker has a 3.6 kg capacity while the Incubating Microplate Shaker can hold up to four standard or deep well plates and is available with a clear polycarbonate lid for viewing samples or with an opaque lid for light sensitive applications.

Standard Features:

- **Microprocessor-Controlled for Consistent Shaking Action**
The variable speed microprocessor control provides consistent, uniform shaking action. The microprocessor will display the last setpoint and will restart if power is interrupted.
- **Triple Eccentric Drive Provides Reliable Service and Continuous Duty**
Triple eccentric drive with permanently lubricated ball bearings and maintenance-free brushless DC motor provides reliable service and continuous duty operation.
- **Safety Features Include Speed Ramping and Overload Protection**
Units slowly increase speed to desired setpoint to avoid splashing. All models feature overload protection. Audible and visual signals activate when the system detects obstruction or tray overload.

Incubating Light Duty Orbital Shakers

Model	ISLD04HDG	ISLDMPHDG	ISLDMPHDGL
Product Description	Incubating Light Duty Orbital Shaker	Incubating Microplate Shaker	Incubating Microplate Shaker with Opaque Lid
Control	Digital		
Motion	Orbital, 3 mm		
Speed Range	100 rpm – 1200 rpm		
Speed Accuracy	± 2%		
Temperature Range	Ambient +5 °C – 65 °C		
Temperature Uniformity	± 0.5 °C at 37 °C		
Timer	1 second – 160 hours		
Capacity	3.6 kg	4 Microplates or 2 Micro-tube Racks	
Working Environment	5 °C – 40 °C, 80% Relative Humidity, non-condensing		
Drive System	Brushless DC Motor; Triple Eccentric		
Tray Construction	Aluminum		
Tray Dimensions (L × W)	279 × 197 mm		
Overall Dimensions (L × W × H)	432 × 279 × 270 mm	432 mm × 279 mm × 197 mm	
Net Weight	11.1 kg	8.9 kg	
Power	230V, 5A, 50/60Hz		
Power Consumption	450 W		

Other Standard Features and Equipment

Spill-resistant design, caution hot indicator, detachable 3-wire cord and plug (included)

Compliance

- **Product Safety:** EN 61010-1, EN 61010-2-010, EN 61010-2-051
- **Electromagnetic Compatibility:** EN 61326-1 Class A, Industrial Environments
- **Compliance Marks:** CE, RCM; TÜV SÜD

Applications

Immunoassays, hybridizations, cell cultures, bacterial & yeast cultures and suspensions, ELISA assays, PCR, enzyme reactions

Accessories

Accessories for ISLD04HDG		
Item No.	Description	Max. per Shaker
30400084	Flask Clamp, 10 mL	35
30400085	Flask Clamp, 25 mL	20
30400086	Flask Clamp, 50 mL	12
30400087	Flask Clamp, 125 mL	8
30400088	Flask Clamp, 250 mL	5
30400099	Flask Clamp PVC 125 mL	8
30400100	Flask Clamp PVC 250 mL	4
30400114	Micro Tube Rack	2
30400115	Test Tube Rack 10-13 mm Ø	1
30400116	Test Tube Rack 14-16 mm Ø	1
30400119	Test Tube Rack For 15 mL Tubes	1
30400120	Test Tube Rack For 50 mL Tubes	1
Accessories for ISLDMPHDG and ISLDMPHDGL		
30400114	Micro Tube Rack	2

Dimensions

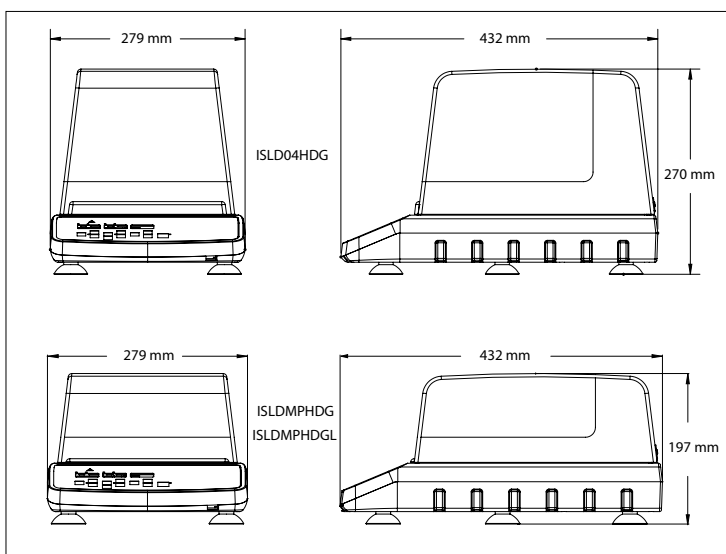

OHAUS Europe GmbH

Im Langacher 44
8606 Greifensee
Switzerland

e-mail: ssc@ohaus.com
Tel: 0041 22 567 53 19
e-mail: tsc@ohaus.com
Tel: 0041 22 567 53 20

www.ohaus.com

The management system governing the manufacture of this product is ISO 9001:2015 certified.

CH16E179

